

Isotop® BL

Block elements for heavy loads

by reinicke
isotop®

Design

Isotop® BL block elements consist of two steel plates and spring elements SD1 - SD9. The number of spring elements depends on the load. All SD elements are cathodolysis coated, which guarantees high corrosion resistance. Special designs are available on request.

Field of application

Isotop® BL block elements have a resonant frequency of about $3,2 \text{ Hz} \approx 192 \text{ min}^{-1}$ and are used for:

- Source isolation of heavy ventilators, fans, extractors, air conditioners, compressors, emergency power units, pumps, textile machines, presses, shaking grates, conveying troughs etc.
- Receiver isolation of sensitive measuring equipment, scales, test beds, control cabinets, transportation bedding etc.
- Percussion isolation of all sorts of machines.

Required data for selection

- Total weight to be absorbed
- Number and location of points of support
- Centre of gravity
- Structural shape of the device (dimensions)
- Direction of load
- Lowest disturbing frequency (rotational speed or number of strokes)

Advantages

- Construction height is identical for all types, which guarantees exchangeability.
- As a result of the open construction, the source is connected to the suspension point only via the spring. The spring element can oscillate in the horizontal plane without restriction.
- The spring is clearly visible, which allows checking of its condition without dismantling. The distance between spring coils is visible under load.
- The form of the steel plates can be adapted to connecting surfaces.



Isotop® BL 4, KTL

Our service

Make use of our know-how on questions about vibration technology. We will gladly consult you and will calculate tailor-made solutions for vibration isolation.

Selection table

DESCRIPTION	NOMINAL RANGE*
Isotop® BL 2 - xx / xx (2 elements)	up to 10,000 N
Isotop® BL 4 - xx / xx (4 elements)	up to 20,000 N
Isotop® BL 6 - xx / xx (6 elements)	up to 30,000 N
Isotop® BL 9 - xx / xx (9 elements)	up to 45,000 N

*the minimal nominal range for all Isotop® block elements is 1,000 N

Remarks on the selection table:

As a result of the possibility of combining Isotop® steel spring vibration isolators of the series SD1 - SD9 (xx/xx in the table), almost all requirements can be accommodated. We design the block elements according to your specific requirements.

BL 2 - xx/xx

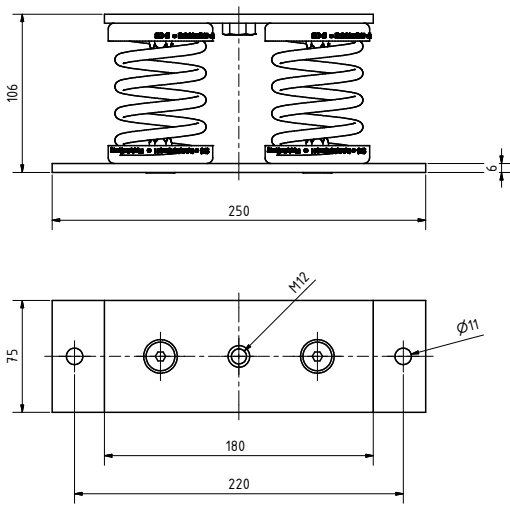

BL 4 - xx/xx

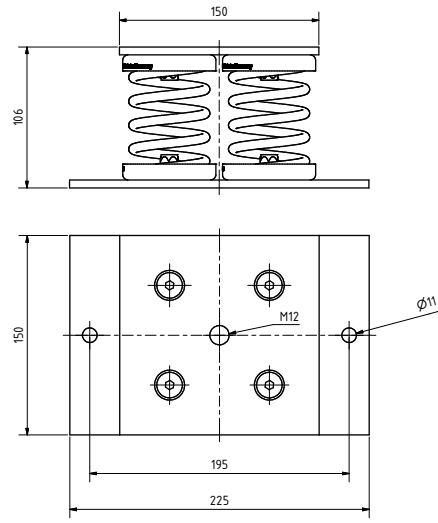

BL 6 - xx/xx

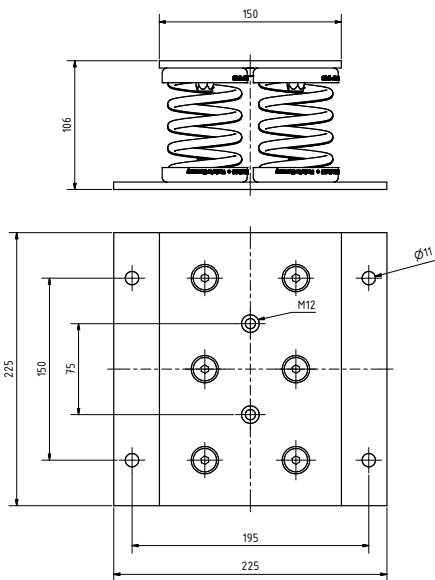

BL 9 - xx/xx

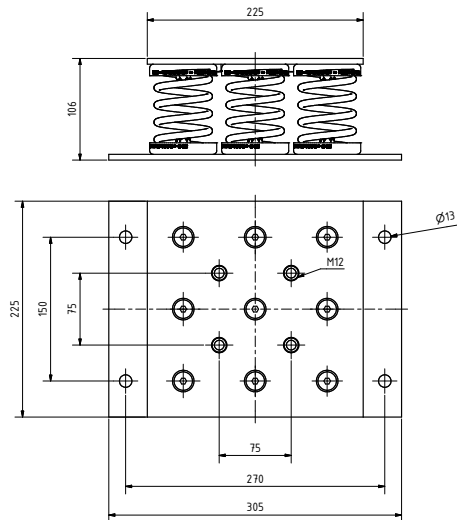

All data indicated are based upon our current knowledge. They may be used as calculation and standard values and are subject to the usual machining tolerances. Subject to change and correction.